

**SECTION - WATER MAIN CROSSING UNDER SEWER**

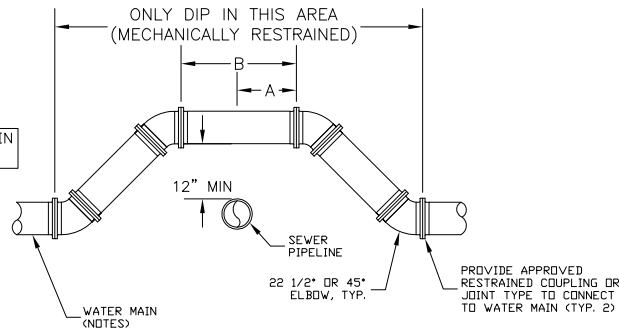

**SECTION - WATER MAIN CROSSING OVER SEWER**

**NOTES:**

1. WATER MAIN SHALL CROSS OVER SEWER WHENEVER POSSIBLE.
2. CROSSINGS SHALL BE MADE AS CLOSE AS POSSIBLE TO PERPENDICULAR (90°), AND AS FAR FROM SEWER PIPELINE JOINTS AS POSSIBLE. WHERE CROSSINGS ARE LESS THAN 70° DISTRICT ENGINEERING SHALL BE ADVISED FOR FIELD DIRECTION.
3. INSIDE NOMINAL DIAMETER OF DUCTILE IRON SEWER PIPE TO BE THE SAME AS THE PIPE TO WHICH IT CONNECTS.
4. DUCTILE IRON SEWER PIPE IS TO BE USED PER THIS DETAIL WHENEVER THE LATERAL OR SEWER SERVICE CROSSES OVER A WATER LINE.
5. CROSSINGS REQUIRING MORE THAN ONE JOINT LENGTH OF DUCTILE IRON SEWER PIPE SHALL HAVE THE JOINTS ENCASED IN 4" OF CONCRETE THAT EXTENDS 6' (MIN) IN EACH DIRECTION FROM THE JOINT.
6. UNLESS OTHERWISE DIRECTED BY DISTRICT, ALL WATERLINE PIPING REQUIRED TO CROSS UNDER SEWER SHALL BE CLASS 350 DIP CML AND BIT COATED.
7. ONE FULL LENGTH OF WATER PIPE SHALL BE LOCATED SO BOTH JOINTS WILL BE AS FAR FROM THE SEWER AS POSSIBLE. NO JOINTS, FITTINGS OR CONNECTIONS ALLOWED WITH IN AREA "B".
8. AT CONTRACTORS DISCRETION THE WATER MAIN TRENCH CAN BE EXCAVATED ON A SLOPE TO INSTALL ("ROPE") MAIN INSTEAD OF USING FITTINGS. JOINT DEFLECTION SHALL NOT EXCEED 2.5".
9. ALL FITTINGS SHALL BE FULLY MECHANICALLY RESTRAINED USING DISTRICT APPROVED METHODS.
10. DUCTILE IRON PIPE SHALL BE WRAPPED WITH 8 MIL POLYETHYLENE SHEETS, 8" LAP REQUIRED.
11. ALTERNATIVES PER STATE OF CALIFORNIA ENVIRONMENTAL HEALTH REGULATIONS MAY BE ALLOWED WITH DISTRICT APPROVAL.

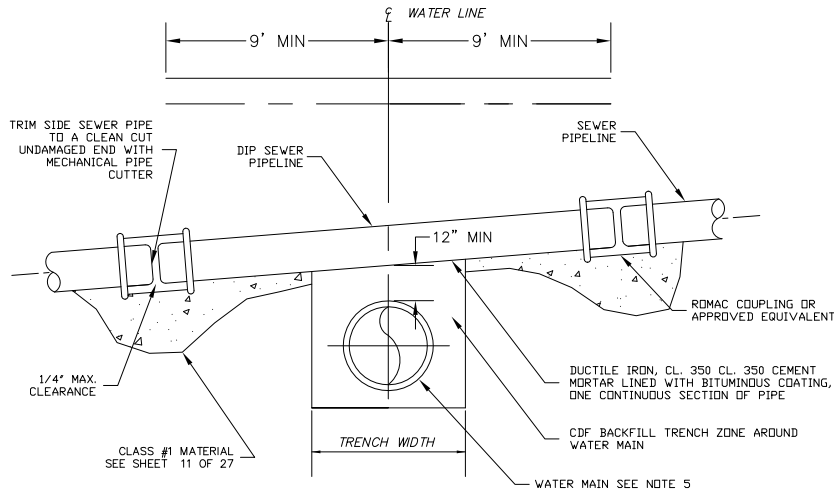

**TYPICAL CROSSING DETAIL WATER LINE UNDER SEWER**

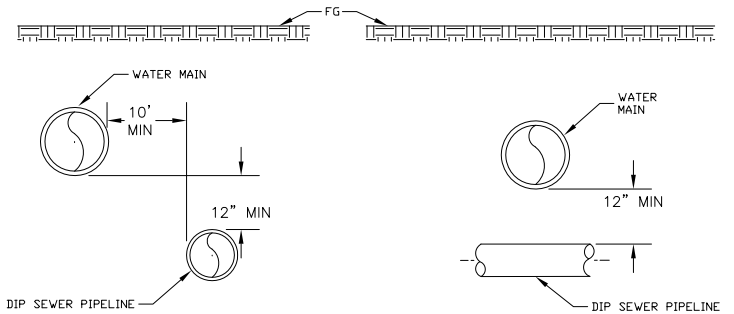

**PARALLEL CONSTRUCTION**

**PERPENDICULAR CONSTRUCTION**

REF: DEPT. OF HEALTH SERVICES "CRITERIA FOR THE SEPARATION OF WATER MAINS AND SANITARY SEWERS", SECTION 64630, TITLE 22, CCR.

**MINIMUM SEPARATION REQUIREMENTS**  
(CONTACT DISTRICT WHEN MIN. SEPARATION CANNOT BE ACHIEVED)

NO	DATE	REVISIONS	APP	BY



**WATER AND SEWER LINE SEPARATIONS**  
SAN JUAN WATER DISTRICT

APPROVED

SCALE: NTS PRINT DATE: 07/13/07 DETAIL NO: SHT 17 OF 27